



IEC-7301/7302

Half-size 3-Slot Wallmount Chassis



System

Construction	Heavy-duty steel chassis
Color	Dark Blue (PANTONE 5395C)
Disk Drive Bay	1 x 5.25" Drive (Slim size, External) 1 x 2.5" Drive (Internal)
Cooling Fan	1 x 6cm/21 CFM with air filter
Control	Power ON/OFF, System reset, Alarm reset
Indicator	1 x Power ON, 1 x HDD activity, 1 x fan failure alarm
Front I/O	2 x USB ports
Temperature	0 ~ 50°C (32 ~ 122°F), operation
Humidity	10 ~ 95%, @40°C (non-condensing)
Regulation	FCC Class A, CE
Net Weight	3.2kg (7 lb)
Gross Weight	3.8kg (8.4 lb)

Backplane

Model Name	System	Expansion Slots
PBI-3S	Single	3 x ISA
PBP-3SA	Single	1 x PISA/2X PCI
PBPCI-3SA	Single	3 x PCI

Power Supply

Model Name	Watt	Input Range	Max. Load	Min. Load
IPS-SNP-8071-A	70W	90 ~ 265V AC	+5V@12A	
(Open frame)		47 ~ 63Hz	+12V@2.5A	
		(Auto)	-12V@0.3A	

Ordering Information

Model Name	w/Backplane	w/Power Supply
IEC-7301-I03A-FR070	PBPCI-3SA	IPS-SNP-8071-A
IEC-7302-P03A-FR070	PBP-3SA	IPS-SNP-8071-A
IEC-7302-S03A-FR070	PBI-3S	IPS-SNP-8071-A

Dimensions

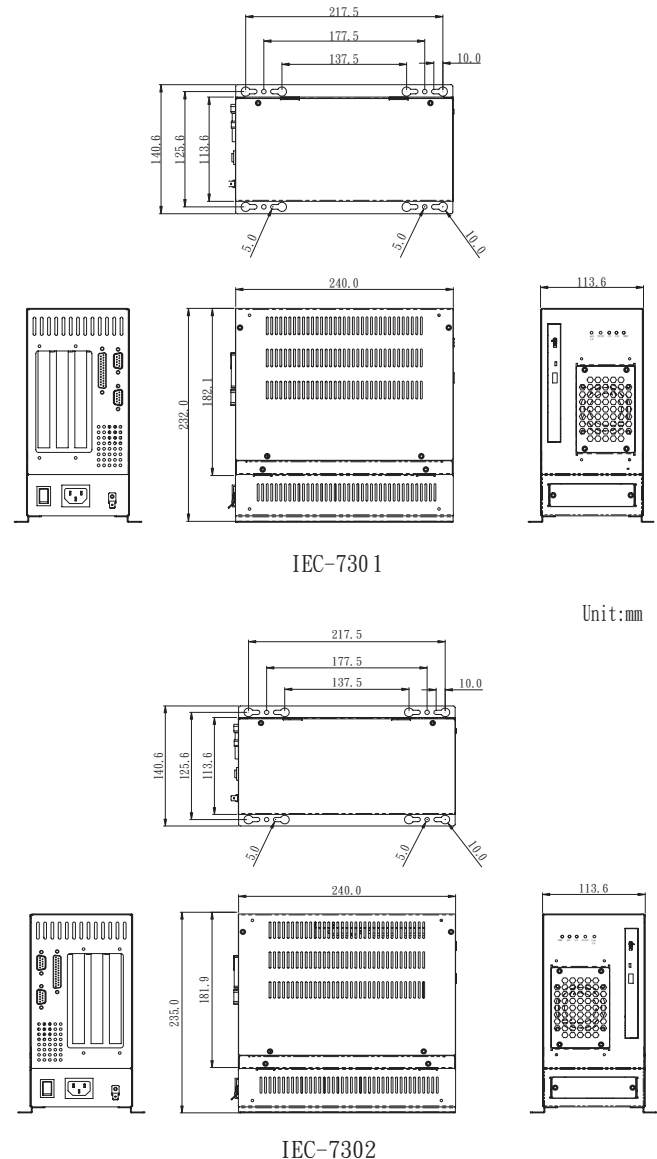

All specifications are subject to change without notice.

Computer on Module

Compact Board

Slot Board

Industrial Motherboard

Wide Temperature

SBC Daughterboard Power Converter Mounting Kit

Rugged Tablet PC

Medical PC

Industrial Panel PC/Monitor

Box PC

Industrial Chassis Backplane/Power supply